

THE VARDA

Basin Mono

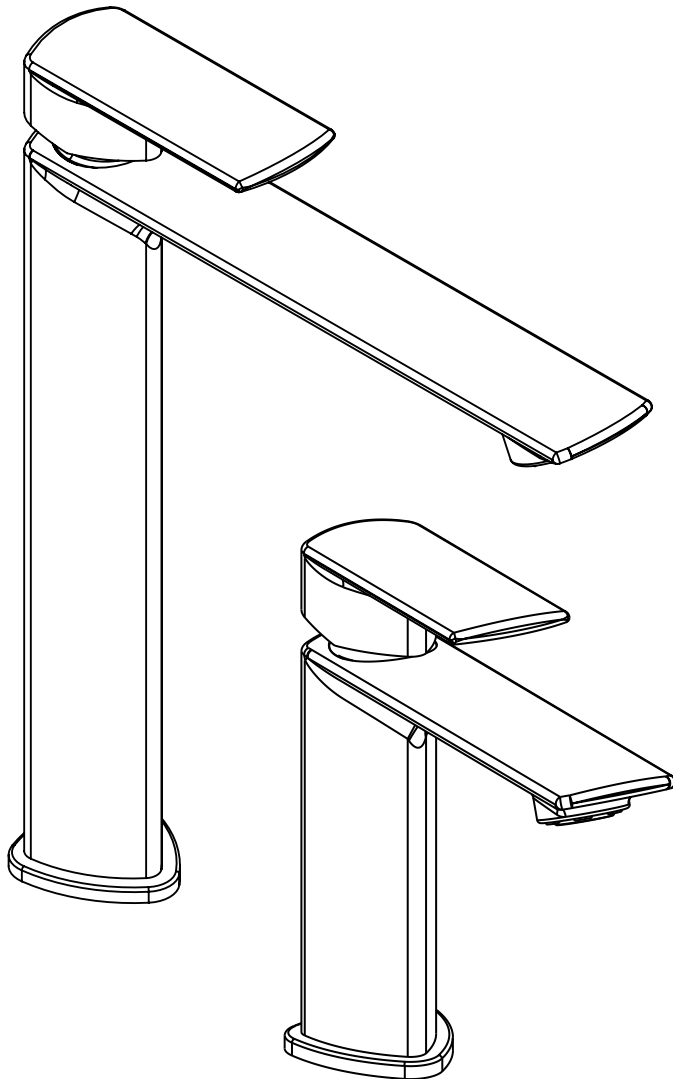

PRODUCT CODES:

TVA110DNx

TVA112DNx



IMPORTANT INFORMATION BEFORE YOU START

Please read carefully and keep this information for further reference.

All products manufactured and supplied by ClearWater are safe provided they are installed, used correctly and receive regular maintenance in accordance with these instructions. If you are in any doubt about your ability to install this product safely you must employ the services of an experienced qualified plumber.

These fittings need to be installed in accordance with, and meet the requirements of the Water Supply (Water Fittings) Regulations 1999 and Scottish Byelaws 2004.

Operating pressure range 1.0 - 5.0 bar.

Maximum static pressure: 10.0 bar.

Note: Nominally equal (balanced) inlet supply pressures are recommended for optimum performance with mixer taps.

Designed to comply with BS EN 200 for single taps / combination taps and BS EN 817 for single lever mixers, for water systems of type 1 and 2 general technical specifications and to be used within systems designed to BS 6700. BS 6700 recommends the temperature of stored water should never exceed 65°C.

A stored water temperature of 60°C is considered sufficient to meet all normal requirements and will minimise the build up of lime scale in hard water areas.

If the fitting is installed at low pressure (tank fed), then the minimum distance from the highest installed position of the outlet to the underside of the cold tank should be at least 2 metres to ensure adequate performance.

DIMENSIONS

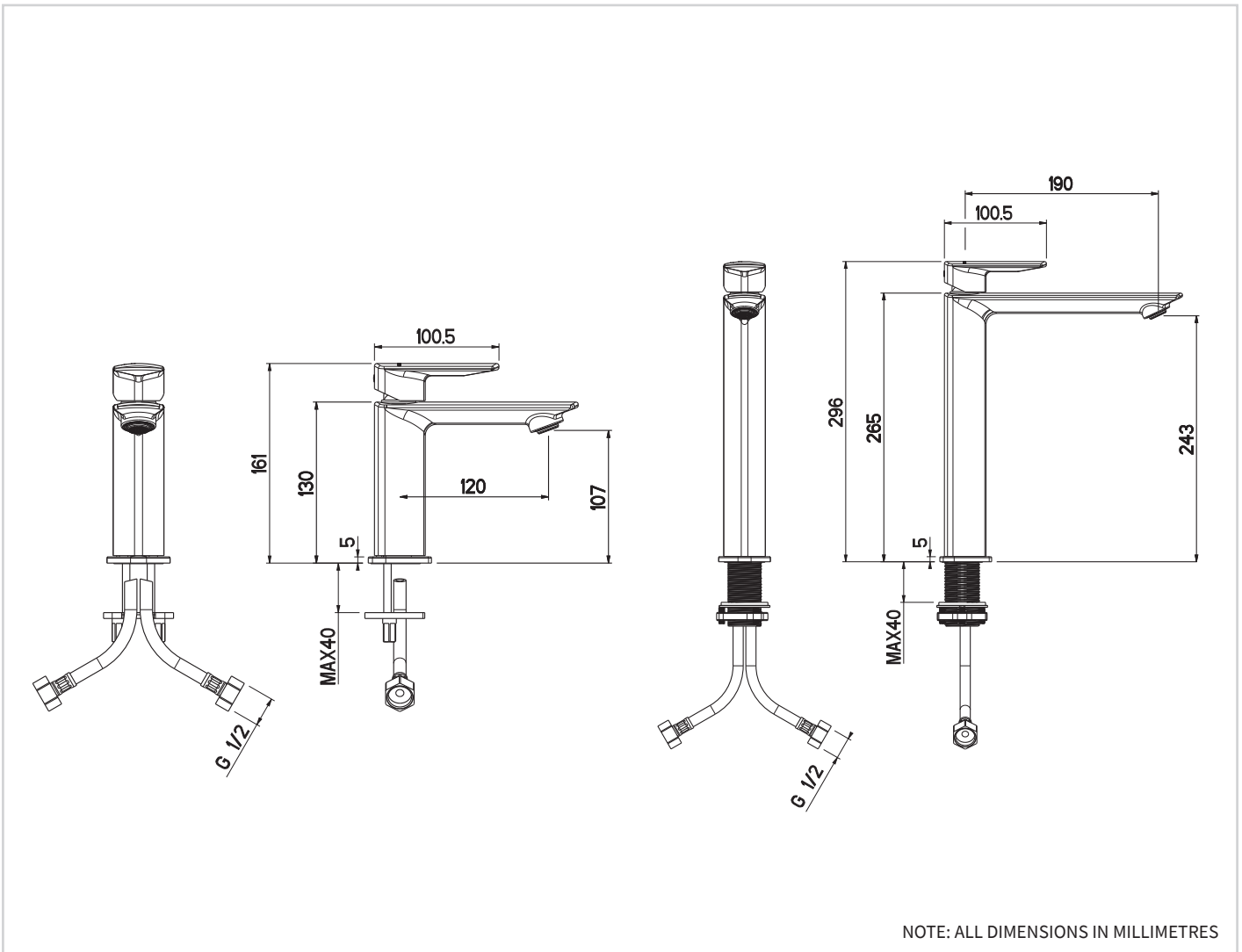

IMPORTANT INFORMATION

Please read carefully and keep this information for further reference.

These taps and mixers should be installed in compliance with the Water Regulations.

Where the supplies are unbalanced, i.e. Hot water from cylinder tank / cold from the mains, approved check valves must be fitted in the supply pipes.

For further details contact your Local Water Authority.

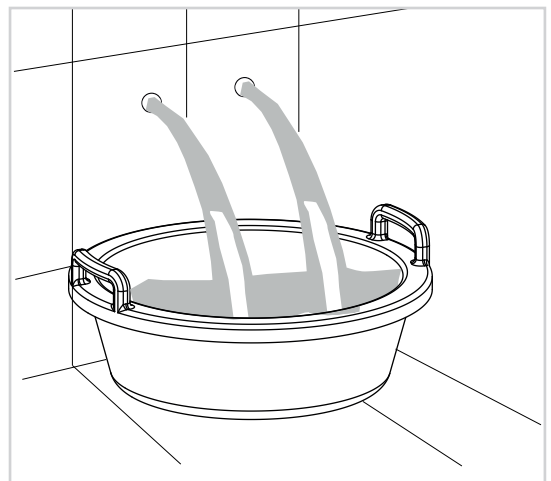

INSTALLATION

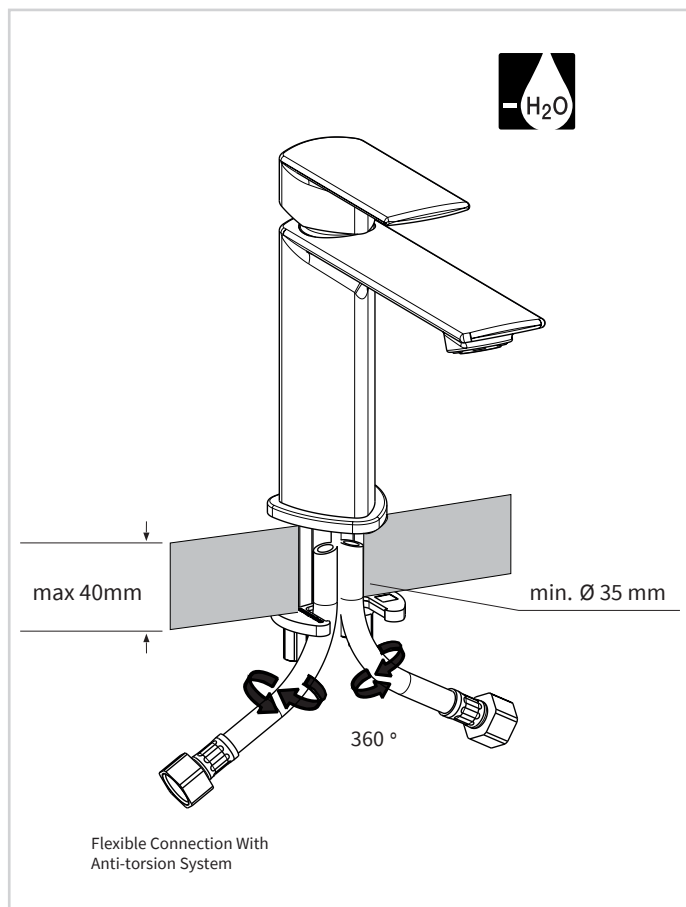
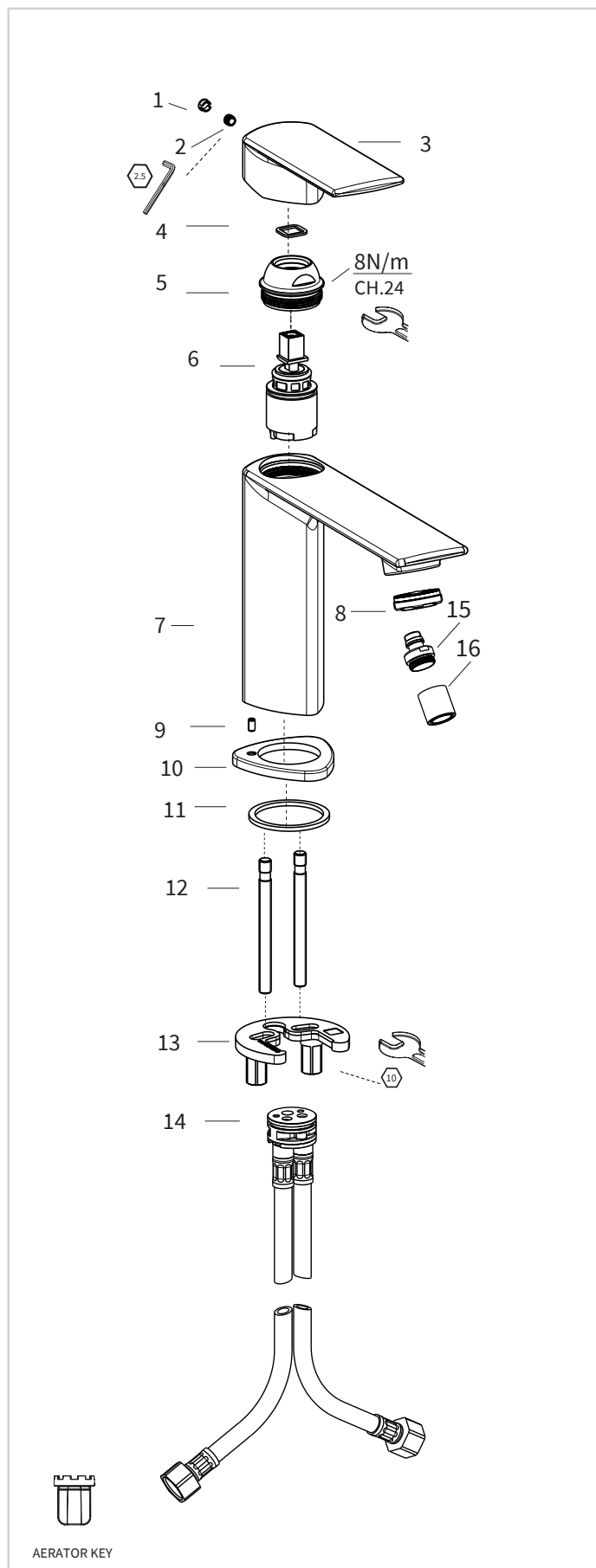

CARE & MAINTENANCE

CLEANING THE CARTRIDGE

The concealed cartridge should give trouble free service, but in the event of any problems, servicing is straight forward.

To remove the cartridge:

Before removing the cartridge, ensure water is isolated.

With a hexagonal key loosen the screw on the end of the lever and remove it. Pull off the handle and unscrew the collar. Using the correct sized spanner, unscrew the cartridge.

Pull out the cartridge taking note of its orientation. Wash the cartridge with clean running water and make sure that any trapped debris has been removed. Dry and lightly grease the seal (only use silicone grease) and replace the cartridge followed by the collar, handle and screw.

CLEANING THE PRODUCT

The material we use in our taps is very durable, nevertheless care should be taken when cleaning them. They should be cleaned only with warm soapy water followed by rinsing with clean water and drying with a soft cloth. All finishes are vulnerable to acid attack and some strong substances such as household cleaners, disinfectants, denture cleaners, hair dyes, wine making, and photographic chemicals can cause the surface to go black or peel.

Note: Never use abrasive detergents or disinfectants or those containing alcohol, hydrochloric acid or phosphoric acid.

AERATOR CLEANING

Before use: Unscrew the aerator and allow the water to run freely until all debris is removed. Screw the aerator back into the spout once all impurities have been flushed from the water supply.

Periodically: Using the key provided in the box, unscrew the aerator from the spout and rinse with clean running water. Once all loose debris and dirt has been cleared, replace the aerator into the spout and tighten with the key provided.

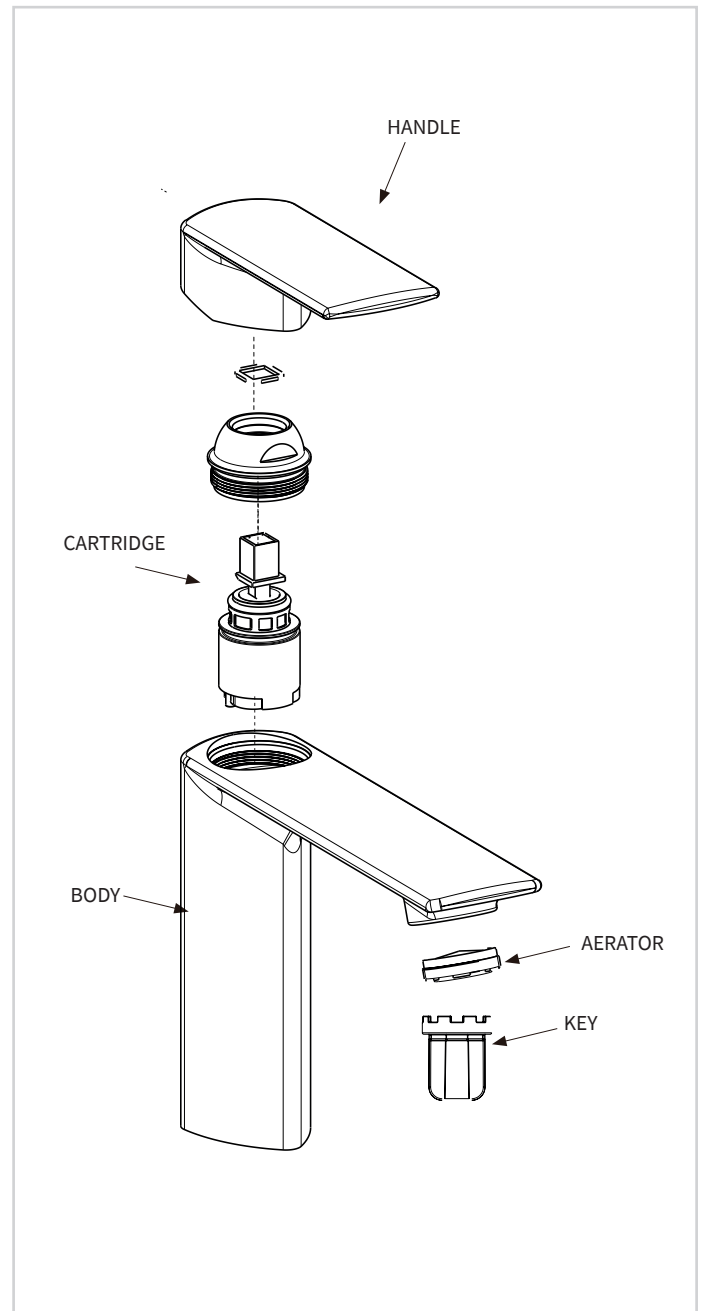

CLEAR[®] WATER

Lake View House
Rennie Drive, Dartford
Kent DA1 5FU
United Kingdom
0345 873 8840
clearwaterinteriors.net